

IRONMAN®

120r

Owner's Manual IRONMAN 120r RECUMBENT

Customer Service
1.800.750.IRON
1.800.750.4766

Ironman Fitness
4009 Distribution Drive
Suite 250
Garland, TX 75041

www.ironmanfitness.com



Table of Contents



Important Safety Information	3
Before You Start	4
Assembly	5-8
Console Instructions	9
Moving Instructions	10
Monitoring Your Heart Rate	11-12
Warm Up Exercises	13
Exploded View	14
Parts List	15
Warranty	16

Important Safety Information



WARNING! Before using this unit or starting any exercise program, consult your physician. This is especially important for persons over the age of 35 and/or persons with pre-existing health problems. The manufacturer or distributor assumes no responsibility for personal injury or property damage sustained by or through the use of this product.

WARNING! To reduce the risk of electrical shock, burns, fire, or other possible injuries to the user, it is important to review this manual and the following precautions before operation.

SAFETY PRECAUTIONS AND TIPS

1. It is the owner's responsibility to ensure that all users of this unit have read the Owner's Manual and are familiar with warnings and safety precautions.
2. This unit has a user maximum capacity of **250** pounds.
3. The unit should only be used on a level surface and is intended for indoor use only. The unit should not be placed in a garage, patio. Ironman Fitness recommends a mat be placed under the unit to protect floor or carpet and for easier cleaning.
4. Wear comfortable, good-quality walking or running shoes and appropriate clothing. Do not use the unit with bare feet, sandals, socks or stockings.
5. Always examine your unit before using to ensure all parts are in working order.
6. Allow the unit to fully stop before dismounting.
7. Pets should never be allowed near the unit.
8. Do not leave children unsupervised near or on the unit.
9. Never operate the unit where oxygen is being administered, or where aerosol products are being used.
10. For safety and to prevent damage to your unit, no more than one person should use the unit at a time.
11. Service to your unit should only be performed by an authorized service representative, unless authorized and/or instructed by the manufacturer.
12. Failure to follow these instructions will void the unit warranty.

Before You Start



Thank you for purchasing the **Ironman 120r Recumbent** ! This quality product you have chosen was designed to meet your needs for cardiovascular exercise. Before you start, please read the Owner's Manual and become familiar with the operation of your new unit.

Remember to take the time to perform the stretching exercises provided to avoid injury.

If you are taking medication, consult your physician to see if the medication will affect your exercise heart rate.

If you have heart problems, you are not active, and/or are over the age of 35 years, do not use the pre-set programs or start an exercise program without first contacting and receiving approval from your physician.

Do not spill liquids on the console. Ironman Fitness recommends a sealed water bottle for beverages consumed while using the unit.

Please review the following drawing below to familiarize yourself with the listed parts.

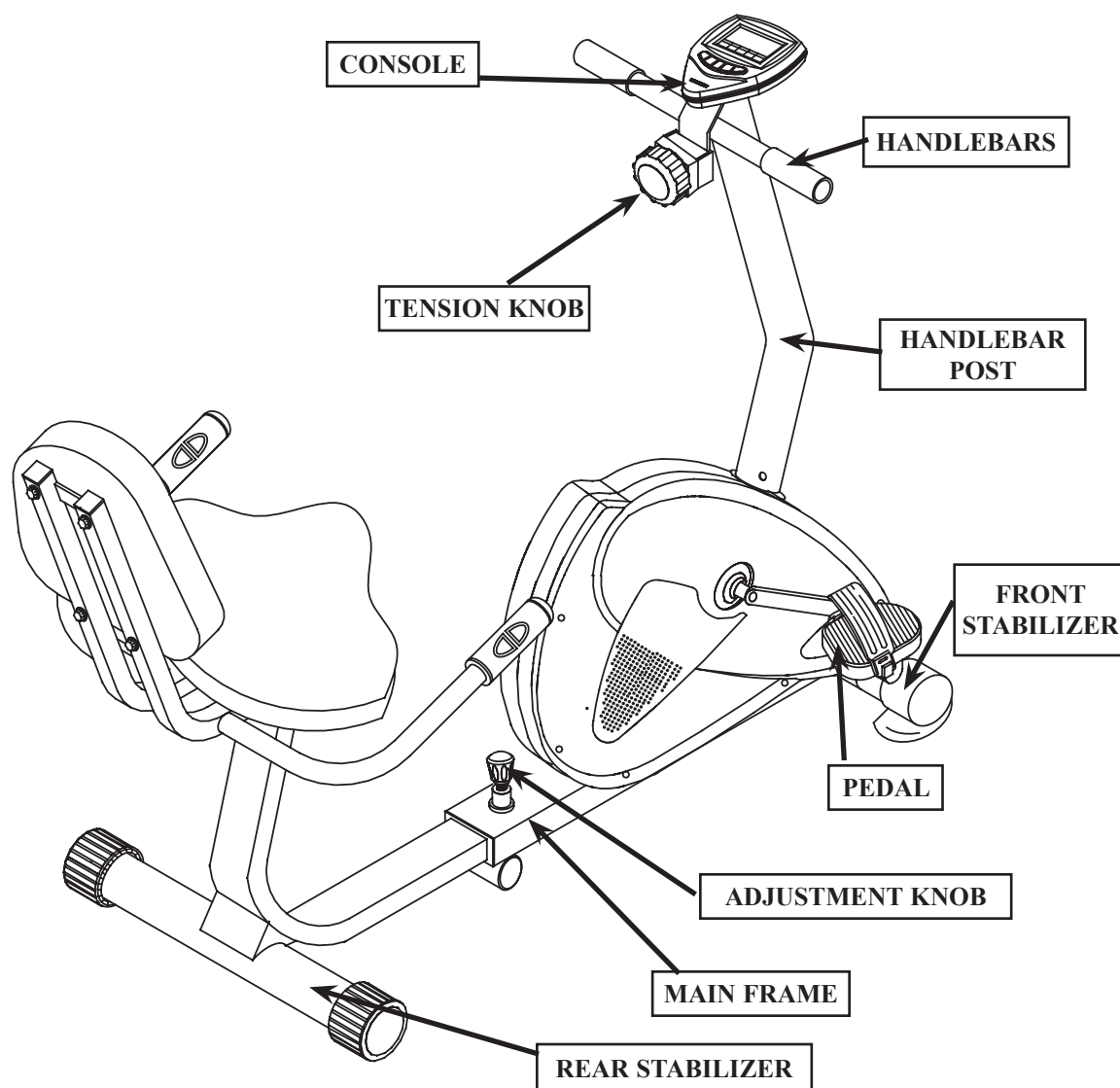

INSTRUCTIONS FOR ASSEMBLY:

Unpack the box in a clear area. Check to make sure all components are present and in good condition. Do not dispose of the packing material until the assembly is completed. Tools have been provided for you to use when assembling this product.

Locate the hardware pack and identify the following parts required for assembly.

Tools:

1. ALLEN WRENCH, M5 AND M6
2. PHILLIPS SCREW DRIVER
3. WRENCH

Main Components:

1. OWNER'S MANUAL
2. MAIN FRAME
3. FRONT STABILIZER ASSEMBLY
4. HANDLEBAR W/PULSE ASSEMBLY
6. HANDLE BAR POST
7. TENSION KNOB
10. CONSOLE ASSEMBLY
11. REAR STABILIZER ASSEMBLY
12. PEDALS LEFT AND RIGHT

Hardware:

1. SCREW M8X1 (49) - Qty 8
2. WASHER (63) - Qty 9
3. CARRIAGE SCREW M8X70 (35) - Qty 2
4. NUT M8 (37) - Qty 2
5. ARC WASHER (36) - Qty 6
6. CARRIAGE SCREW M8X40 (48) - Qty 4
7. NYLOCK NUT M8 (60) - Qty 6
8. HEX HEAD SCREW M6X40 (50) - Qty 8
9. WASHER (62) - Qty 8
10. SCREW M8X15 (49) - Qty 8
11. SCREW M5X10 (65) - Qty 1

FIGURE 1

Step 1:

Loosen the adjustment knob (41) on the front frame (1). Slide the rear frame backward and secure with the adjustment knob (41).

Step 2:

Attach the rear stabilizer (3) onto the rear frame with screws (49) and washers (63).

Step 3:

Attach the front stabilizer (34) onto the main frame with carriage bolts (35), cap nuts (37) and washers (36).

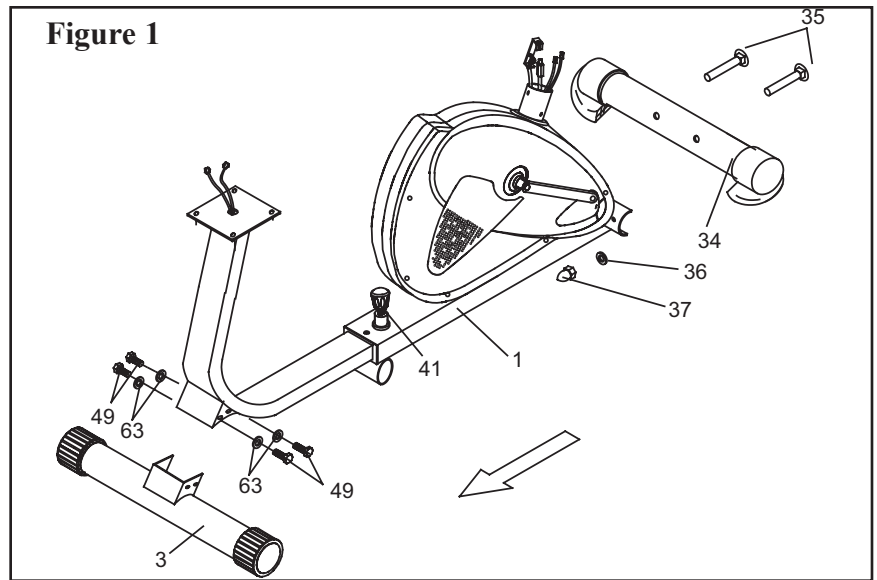

FIGURE 2

Step 1:

Connect Cables (76) to Cables (42).

Step 2:

Attach the seat frame (4) onto the rear frame with carriage bolts (48), nylon lock nuts (60) and washers (63).

Note: Be careful not to pinch cables.

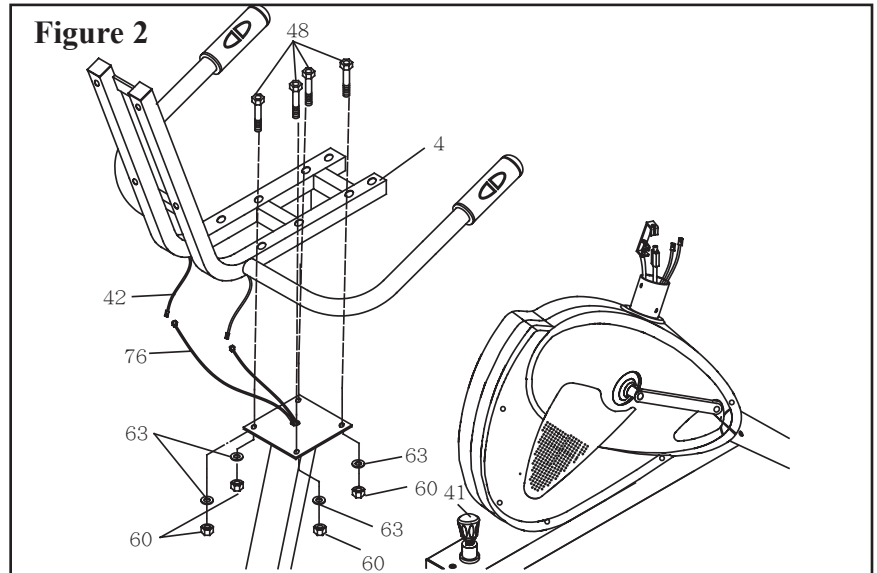

FIGURE 3

Step 1:

Attach the seat (5) onto the seat frame (4) with bolts (50) and washers (62).

Step 2:

Attach the back cushion (6) onto the seat frame (4) with bolts (50) and washers (62).

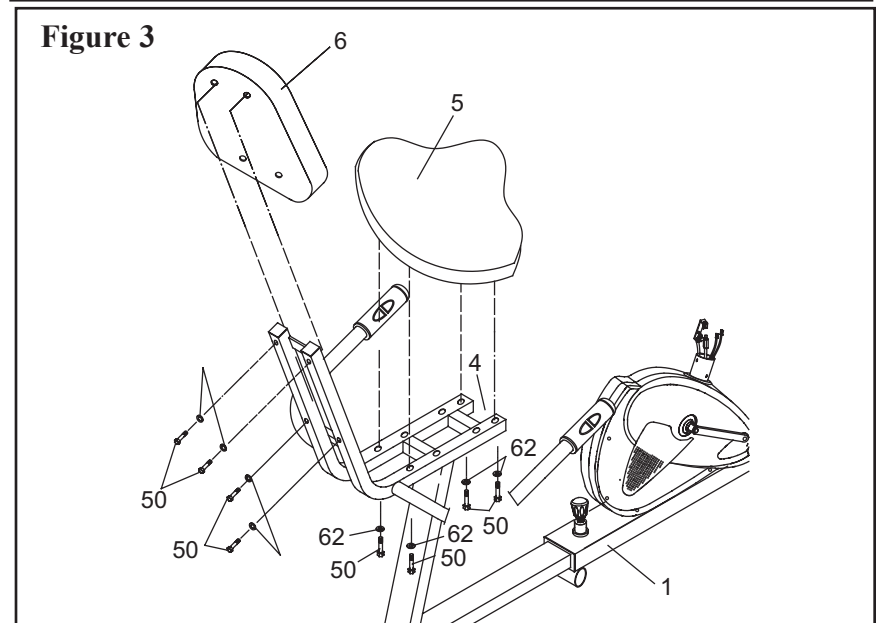

Assembly

FIGURE 4:

Step 1:

Thread the right pedal (39) onto the right side of the crank (8) as shown. Tighten the pedal securely. Select the right pedal strap which has “R” marked on the bottom side of the strap. Snap the three hole end onto the inside edge of the right pedal (39). Snap the other three hole end onto the outside edge of the right pedal (39). Select adjustment holes which allow your foot to be easily removed from the pedals.

Step 2:

Repeat with the left pedal and strap.

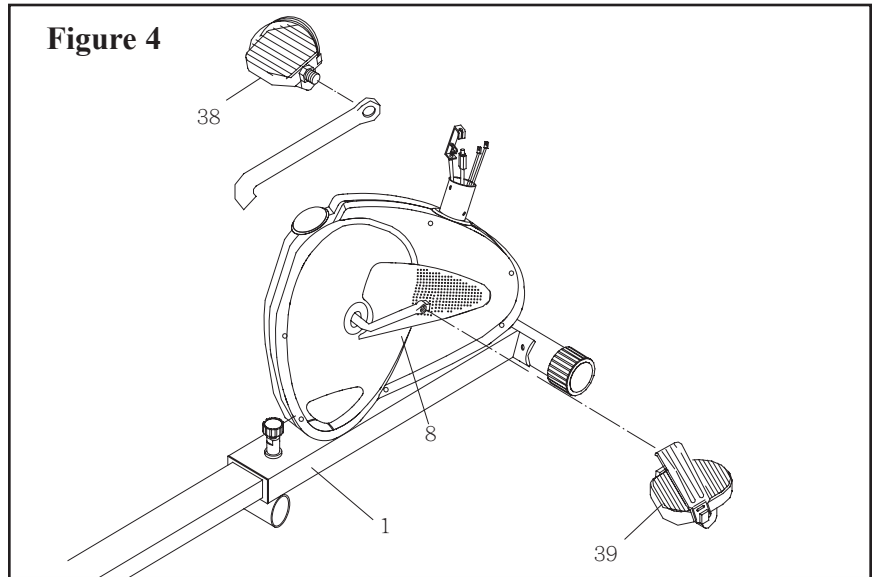

FIGURE 5

Step 1:

Insert the sensor wire (packed with tension controller) from the top of the handlebar post (75). Connect the wires per Figure 5.

Step 2:

Fix the handlebar post (75) onto the main frame (1) with screws (49) and arc washers (36).

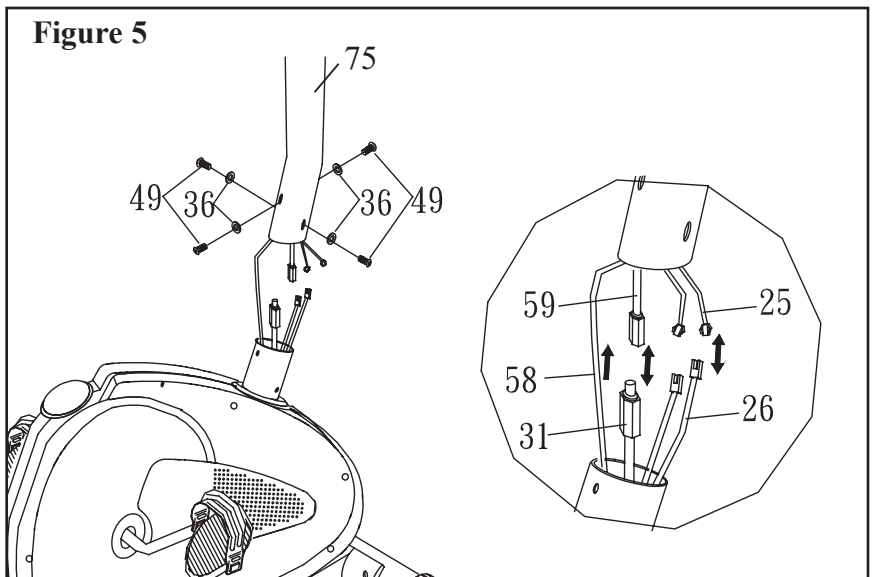
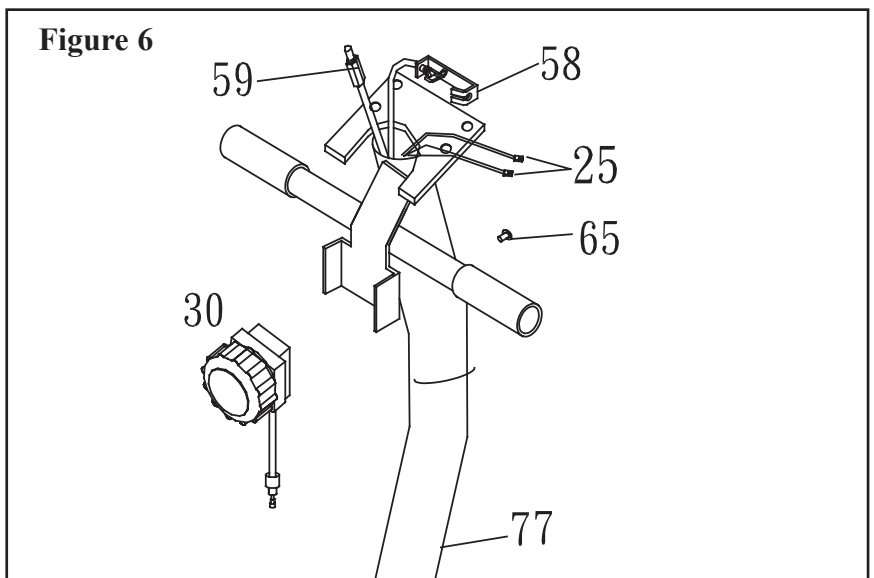

FIGURE 6

Step 1:

Connect Tension Knob (30) to Resistance Cable (58). Refer to Figure 6a,6b,and 6c for detailed instructions. Using one Screw (65) attach Tension Knob to Upright Post Assembly (77).



Assembly

FIGURE 6a, 6b,6c: Connect the Tension Knob to the Resistance Cable. Fit the Resistance Control Cable into the slot of the Tension Knob. Pull the brass end of the Resistance Control Cable over the lip of the Tension Knob Bracket. The connection should look like *Figure 6c* when completed.

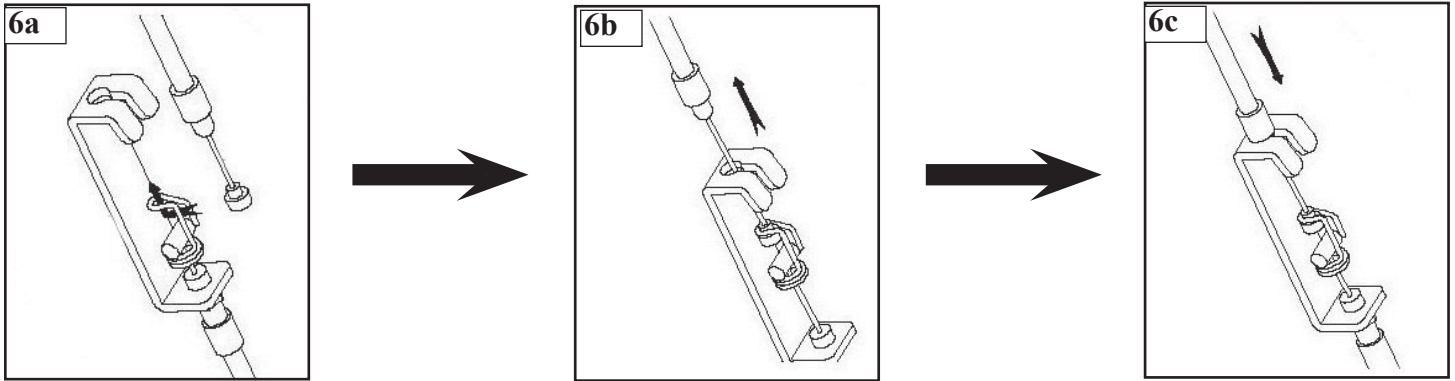

FIGURE 7:

Step 1:

Connect Sensor and Tension Cables to Console as shown in Figure 7.

Step 2:

Attach Console (33) to Upright using four Screws. **Note:** *The four Screws will already be installed into the back of Console(33) when you remove it from the box.*

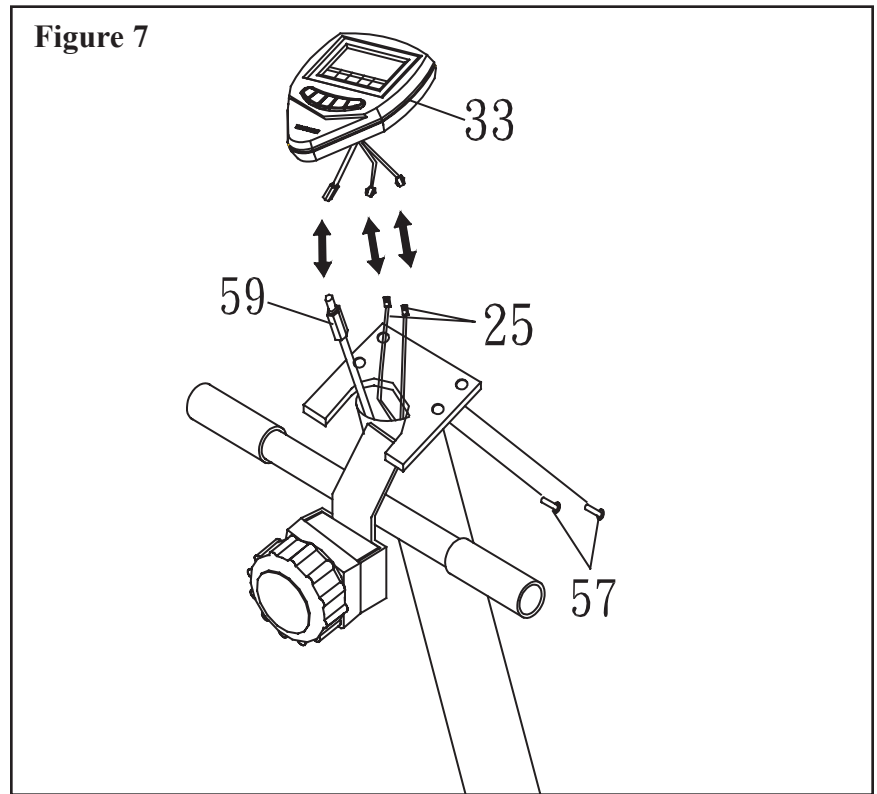

CONGRATULATIONS!!!!!!

You have completed Assembly of your New Ironman 120r Recumbent.

Console Overview



CONSOLE BUTTONS:

ENTER/RESET:

Press to begin workout or change console settings.

PULSE/RECOVERY:

Press to run Pulse program.

DOWN:

Press to set or change TIME, DISTANCE or CALORIES.

UP:

Press to set or change TIME, DISTANCE or CALORIES.

GENERAL INFORMATION:

1. The console will shut off after it detects 4 minutes no activity.
2. Battery Specifications: Two 1.5V AA Batteries
3. If display is illegible or only partial segments appear, remove batteries, wait for 15 seconds and reinstall batteries. If display is still illegible, you may need new batteries.

FUNCTIONS:

TIME:

This will count up from 00:00 up to 99:50 if you do not enter a preset time.
If you do enter a preset time the console will count down from the time you set to 0:00.

SPEED:

Displays the current exercise speed on the console screen.

DISTANCE:

This will count the accumulated distance during a workout.
If you enter a preset target the console will count from that distance set down to zero.

CALORIE:

This will count the accumulated calorie consumption during a workout.
If you enter a preset target the console will count from the amount set down to zero.
Note: This data is an estimate only and should be used as a comparison over several exercise sessions.

PULSE:

This will display your current heart rate within 5 seconds of holding the handgrip.
Note: To obtain an accurate reading, hold the handgrips with both hands.

PULSE RECOVERY:

To monitor your improvement after each exercise the console is equipped with a special function known as RECOVERY. Before ending an exercise press the RECOVERY button. The console will stop all function displays except TIME, which will count down from 00:60 to 00:00. Once the time reaches 00:00 the console will show a Recovery Status with a grade of F1 to F6, F1 being the best and F6 being the worst. Press the PULSE RECOVERY button again to return to the main display.

Moving Instructions

CAUTION! TO REDUCE THE POSSIBILITY OF INJURY WHILE LIFTING, BEND YOUR LEGS AND KEEP YOUR BACK STRAIGHT. AS YOU LEAN THE UNIT, LIFT USING YOUR LEGS, NOT YOUR BACK.

First, kneel down and grasp the rear support tube with both hands as shown in Figure 1. Next, with a firm grasp on rear support tube stand up bringing the rear of the bike up in the air and tilt the unit until it rolls freely on the transport wheels. Using extreme caution, move the unit to the desired location as shown in Figure 2. Do not attempt to move the unit over an uneven or rough surface.

Note: *The unit you purchased may not be identical to the one pictured.*

Figure 1



Figure 2



Note: This unit may not be identical to your unit.

Monitoring Your Heart Rate



Monitoring Your Heart Rate

To obtain the greatest cardiovascular benefits from your exercise workout, it is important to work within your target heart rate zone. The American Heart Association (AHA) defines this target as 60%-75% percent of your maximum heart rate.

Your maximum heart rate may be roughly calculated by subtracting your age from 220. Your maximum heart rate and aerobic capacity naturally decreases as you age. This may vary from one person to another, but use this number to find your approximate effective target zone. For example, the maximum heart rate for an average 40 year-old is 180 bpm. The target heart rate zone is 60%-75% of 180 or 108-135 bpm. See ***Fitness Safety*** below.

Before beginning your workout, check your normal resting heart rate. Place your fingers lightly against your neck, or against your wrist over the main artery. After finding your pulse, count the number of beats in 10 seconds. Multiply the number of beats by six to determine your pulse rate per minute. We recommend taking your heart rate at these times; at rest, after warming up, during your workout and two minutes into your cool down, to accurately track your progress as it relates to better fitness.

During your first several months of exercising, the AHA recommends aiming for the lower part of the target heart rate zone-60%, then gradually progressing up to 75%.

According to the AHA, exercising above 75% of your maximum heart rate may be too strenuous unless you are in top physical condition. Exercising below 60% of your maximum will result in minimal cardiovascular conditioning.

Check your pulse recovery rate – If your pulse is over 100 bpm five minutes after you stop exercising, or if it's higher than normal the morning after exercising, your exertion may have been too strenuous for your current fitness level. Rest and reduce the intensity next time.

Fitness Safety *The target heart rate chart indicates average rate zones for different ages. A variety of different factors (including medication, emotional state, temperature and other conditions) can affect the target heart rate zone that is best for you. Your physician or health care professional can help you determine the exercise intensity that is appropriate for your age and condition.*

(MHR) = Maximum Heart Rate

(THR) = Target Heart Rate

$220 - \text{age} = \text{maximum heart rate (MHZ)}$

$\text{MHZ} \times .60 = 60\% \text{ of your maximum heart rate.}$

$\text{MHZ} \times .75 = 75\% \text{ of your maximum heart rate.}$

For example, if you are 30 years old, your calculations will be as follows:

$220 - 30 = 190$

$190 \times .60 = 114$ (low end or 60% of MHZ)

$190 \times .75 = 142$ (high end or 75% of MHZ)

30 year-old (THR) Target Heart Rate would be 114-142

See Heart Rate Table (**on page 14**) for additional calculations.

TARGET HEART RATE ZONE

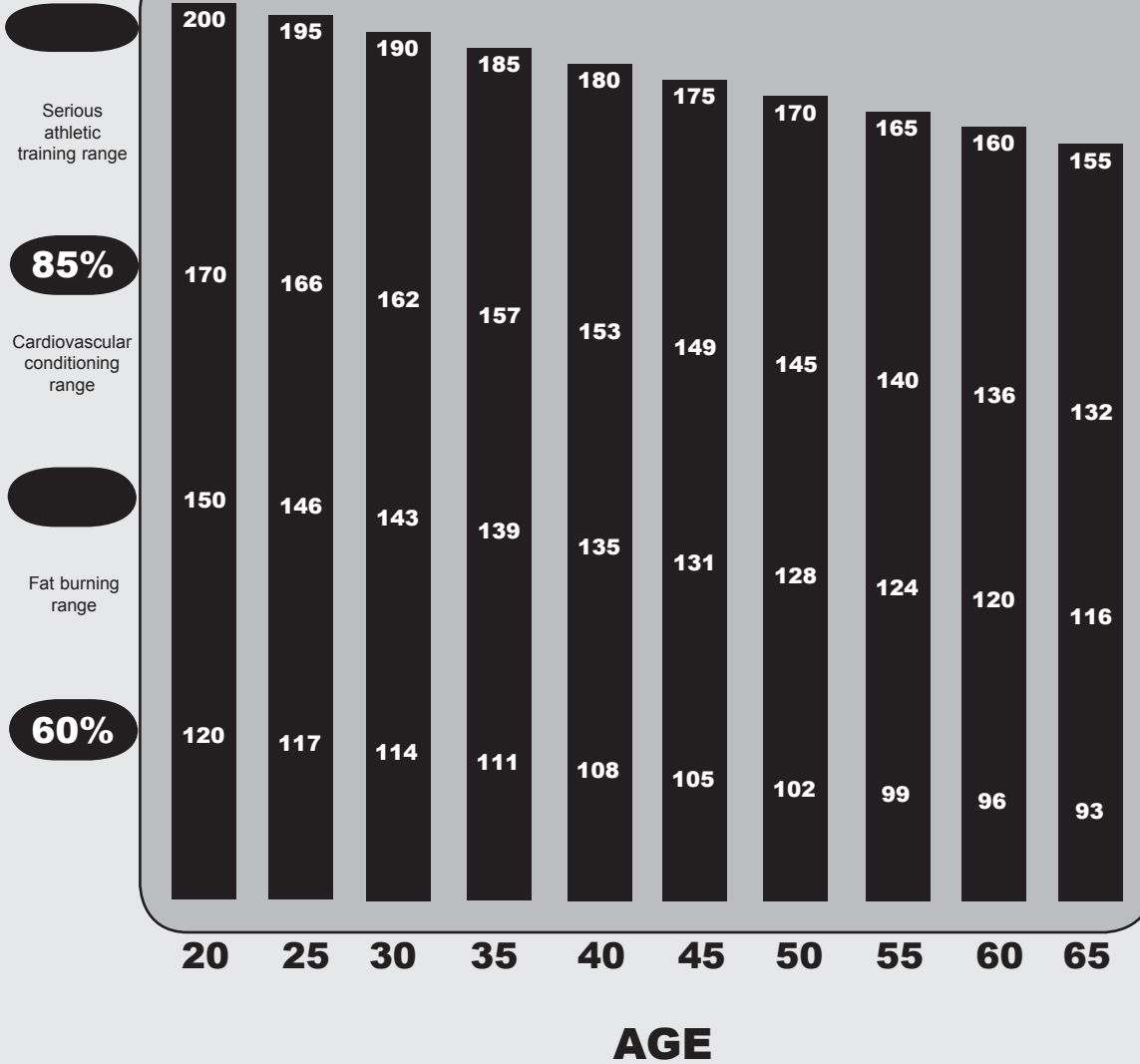

EXERCISE GUIDELINES

WARNING! Before beginning this or any exercise program, you should consult your physician. This is especially important for individuals over the age of 35 or individuals with pre-existing health problems.

Warming up prepares the body for the exercise by increasing circulation, supplying more oxygen to the muscles and raising body temperature. Begin each workout with 5 to 10 minutes of stretching and light exercise to warm up. The photos on this page show several forms of basic stretching you may perform before your workouts. In order to achieve an adequate warm-up, perform each stretch three times.

TOE TOUCH STRETCH

Stand bending your knees slightly and slowly bend forward from your hips. Allow your back and shoulders to relax as you reach down toward your toes as far as possible. Hold for 15 counts, then relax. This will stretch your hamstrings, back of knees, and back.



HAMSTRING STRETCH

Sit with one leg extended. Bring the sole of the opposite foot toward you and rest it against the inner thigh of your extended leg. Reach toward your toes as far as possible. Hold for 15 counts, then relax. This will stretch your hamstrings, lower back, and groin.



CALF/ACHILLES STRETCH

With one leg in front of the other, reach forward and place your hands against a wall. Keep your back leg straight and your back foot flat on the floor. Bend your front leg, lean forward and move your hips toward the wall. Hold for 15 counts, then relax. To cause further stretching of the Achilles tendon, bend your back leg as well. This will stretch your calves, Achilles tendons, and ankles.

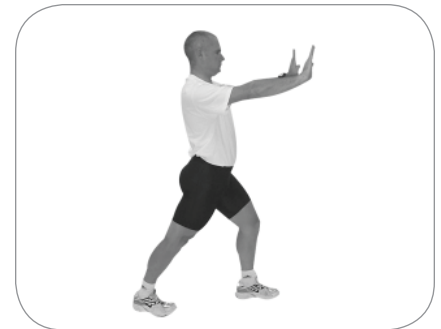

QUADRICEPS STRETCH

With one hand against a wall for balance, reach back and grasp one foot with your other hand. Bring your heel as close to your buttocks as possible. Hold for 15 counts, then relax. This will stretch your quadriceps and hip muscles.



INNER THIGH STRETCH (not pictured)

Sit with the soles of your feet together and your knees outward. Pull your feet toward your groin area as far as possible. Hold for 15 counts, then relax. This will stretch your quadriceps and hip muscles.

Exploded View

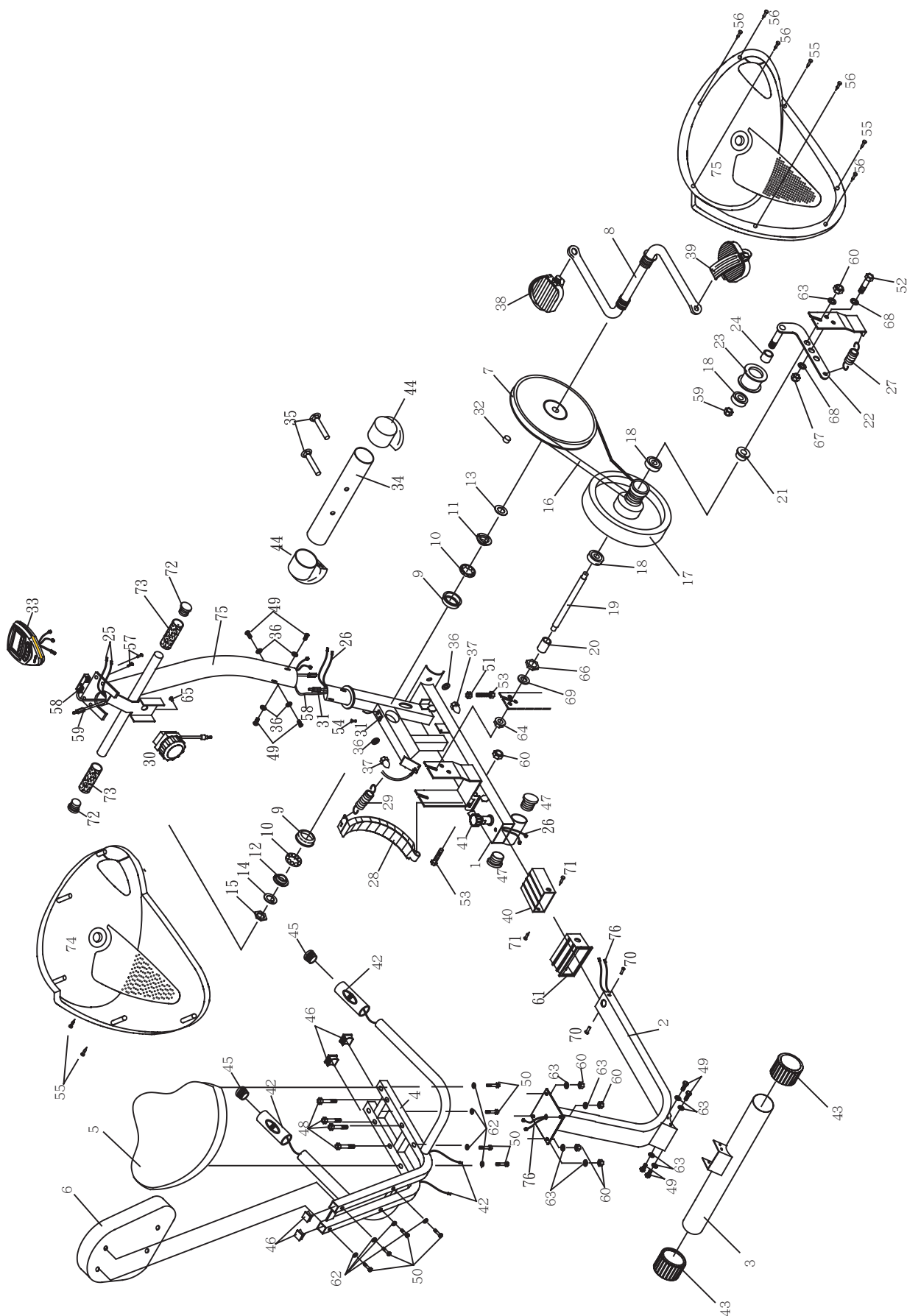

Parts List



Ironman 120r Recumbent Parts List Rev A

Ref #	Part #	Description	Qty
1	323-00334	MAIN FRAME, 120R	1
2	323-00335	RAIL TUBE,120R	1
3	323-00336	REAR STABILIZER 60X600, 120R	1
4	323-00338	REAR FRAME, 120R	1
5	328-00059	SEAT PAD, 120R	1
6	328-00060	BACK PAD, 120R	1
7	311-00056	PULLEY 270MM, DCV/120E/R	1
8	330-00075	CRANK 1/2" ONE PC DCV5.2R/120R	1
9	331-00071	BALLBEARING HOUSING, DCV5.2R/120R	2
10	331-00070	BALLBEARING, DCV5.2R/120R	2
11	331-00074	OUTSIDE BEARING COLLAR, DCV5.2R/120R	1
12	331-00073	INSIDE BEARING COLLAR, DCV5.2R/120R	1
13	302-00667	WASHER,24X40X2.4	1
14	302-00659	CURVE WASHER, 23X35X2	1
15	302-00660	HEX HEAD SCREW #15	1
16	304-00002	BELT, J6 430	1
17	311-00055	FLY WHEEL #17	1
18	331-00072	BEARING 6000ZZ	3
19	330-00074	AXLE OF FLY WHEEL 9.98X143, D5.2U/R/120R	1
20	302-00662	SPACER OF FLY WHEEL 10X13X10	1
21	302-00005	GREASED WHEEL 8X13X7, DCV5.2R/120R	1
22	319-00104	IDLER WHEEL PLATE #22	1
23	311-00029	IDLER WHEEL ALL INNOFIT UNITS	1
24	302-00663	SPACER OF IDLER WHEEL #24	1
25	313-00028	PULSE WIRE (1)	1
26	313-00064	PULSE WIRE(2)	1
27	302-00665	SPRING OF IDLER WHEEL #27	1
28	319-00099	ARC MAGNET PLATE #28	1
29	302-00664	SPRING OF ARC MAGNET #29	1
30	310-00165	TENSION KNOB DCV5.2R	1
31	313-00057	SPEED SENSOR	1
32	302-01145	MAGNET, 12.5 * 5	1
33	307-00086	CONSOLE, 120E/120R	1
34	323-00337	FRONT STABILIZER 60X350, 120R	1
35	302-00658	CARRIAGE SCREW M8X70	2
36	302-00657	ARC WASHER 8X19X1.5	6
37	302-00515	NUT M8	2
38	306-00633	LEFT PEDAL, 120R	1
39	306-00634	RIGHT PEDAL, 120R	1
40	306-00200	BUSHING OF MAIN FRAME	1
41	310-00001	ADJUSTABLE KNOB U/R/H CM520/530/580 DCV5	1
42	313-00028	PULSE WIRE (1)	2
43	306-00565	FRONT STABILIZER ENDCAP, DCV5.2EL	2
44	306-00564	REAR STABILIZER ENDCAP, DCV5.2R	2
45	306-00459	HANDLEBAR TUBE CAP, DCV5.2R	2
46	306-00201	SEAT FRAME TUBE CAP	4
47	306-00445	CAP 38.1, DCV5.2R/120R	2
48	306-00460	CARRIAGE SCREW M8X40, DCV5.2R/120R	4
49	302-00670	SCREW M8X15	8
50	302-00671	HEX HEAD SCREW M6X40	8
51	302-00672	SCREW M8	1
52	302-00673	HEX HEAD SCREW 3/8"X26	1
53	302-00674	HEX HEAD SCREW M8X60	2
54	302-00675	SCREW M3X8	1
55	302-00676	SCREW#55	4
56	302-00677	SCREW#56	5
57	302-00678	SCREW M5X10	2
58	313-00027	EXTENSION WIRE	1
59	302-00679	NYLOCK NUT M10	1
60	302-00680	NYLOCK NUT M8	6
61	306-00245	RAIL TUBE CAP, DCV5.2R	1
62	302-00687	WASHER 6X13X1.0	8
63	302-00681	WASHER 8X19X1.5	9
64	302-00682	SCREW 3/8"	1
65	302-00683	SCREW M5X10	1
66	302-00684	BC NUT 3/8"	1
67	302-00685	NYLOCK NUT 3/8"	1
68	302-00686	WASHER 10X26X2.0	2
69	302-00690	WASHER 10X19X1.5	1
70	302-00688	SCREW M4X16	2
71	302-00689	SCREW M4/8	2
72	306-00203	HANDLEBAR TUBE CAP	2
73	310-00166	FOAM GRIP DCV5.2R	2
74	305-00096	LEFT COVER, 120R	1
75	305-00097	RIGHT COVER, 120R	1
76	313-00147	PULSE WIRE (3)	1
77	323-00333	CONSOLE TUBE, 120R	1
#	302-01148	BOLT PACK DCV5.2R/120R	1
#	315-00049	OWNER'S MANUAL 120R	1
#	310-00192	TENSION KNOB ASSEMBLY, 120R	1

Warranty Information



IRONMAN FITNESS 120r LIMITED WARRANTY

Residential Warranty

Frame: Lifetime

Parts: 1 Year

Labor: None

This Limited Warranty applies in the United States and Canada to products manufactured or distributed by Ironman Fitness (“Ironman”) under the Ironman brand name. The warranty period to the original purchaser is listed above in the table.

Ironman warrants that the Product you have purchased for use from Ironman or from an authorized Ironman reseller is free from defects in materials or workmanship under normal use during the warranty period. Your sales receipt, showing the date of purchase of the Product, is your proof of purchase. This warranty only extends to you, the original purchaser. It is not transferable to anyone who subsequently purchases the Product from you. It excludes expendable parts (wear items). Wear items pertain to components that might need to be replaced due to normal wear and tear. These items vary per product but will include pedal straps, seats, grips, chains, bottom bracket assemblies, pads, etc. Please contact an Ironman customer service representative for specifics on wear items. This Limited Warranty becomes VALID ONLY if the product is purchased through an Ironman Fitness authorized dealer unless otherwise authorized by Ironman Fitness in writing.

During the warranty period Ironman will repair or replace (at Ironman’s option) the product if it becomes defective, malfunctions, or otherwise fails to conform with this Limited Warranty under normal use. In repairing the Product, Ironman may replace defective parts, or at the option of Ironman, serviceable used parts that are equivalent to new parts in performance. All exchanged parts and Products replaced under this warranty will become the property of Ironman. Ironman reserves the right to change manufacturers of any part to cover any existing warranty.

This warranty DOES NOT COVER shipping charges, export taxes, custom duties and taxes, or any other charges associated with transportation of the parts or Product.

To obtain warranty service, you must contact an Ironman authorized retailer, service technician or Ironman Fitness at our phone number located in this manual. Any parts determined to be defective must be returned to Ironman to obtain warranty service. You must prepay any shipping charges, export taxes, custom duties and taxes, or any other charges associated with transportation of the parts or Product. In addition, you are responsible for insuring any parts or Product shipped or returned. You assume the risk of loss during shipment. You must present Ironman with proof-of-purchase documents (including the date of purchase). Any evidence of alteration, erasing or forgery of proof-of-purchase documents will be cause to void this Limited Warranty.

This warranty does not extend to any product not purchased from Ironman or from an authorized Ironman reseller. This Limited Warranty does not extend to any Product that has been damaged or rendered defective; (a) as a result of accident, misuse, or abuse; (b) by the use of parts not manufactured or sold by Ironman; (c) by modification of the Product or normal wear and tear; (d) operation on incorrect power supplies; or (e) as a result of service by anyone other than Ironman, or an authorized Ironman warranty service provider. Product on which the serial number has been defaced or removed is not eligible for warranty service. Should any Product submitted for warranty service be found ineligible, an estimate of repair cost will be furnished and the repair will be made if requested by you upon Ironman’s receipt of payment or acceptable arrangements for payment.

EXCEPT AS EXPRESSLY SET FORTH IN THIS WARRANTY, IRONMAN MAKES NO OTHER WARRANTIES, EXPRESSED OR IMPLIED, INCLUDING ANY IMPLIED WARRANTIES OF MERCHANTABILITY AND FITNESS FOR A PARTICULAR PURPOSE. IRONMAN EXPRESSLY DISCLAIMS ALL WARRANTIES NOT STATED IN THIS LIMITED WARRANTY. ANY IMPLIED WARRANTIES THAT MAY BE IMPOSED BY LAW ARE LIMITED TO THE TERMS OF THIS LIMITED WARRANTY. NEITHER IRONMAN NOR ANY OF ITS AFFILIATES SHALL BE RESPONSIBLE FOR INCIDENTAL OR CONSEQUENTIAL DAMAGES. SOME STATES DO NOT ALLOW LIMITATIONS ON HOW LONG AN IMPLIED WARRANTY LASTS OR THE EXCLUSION OR LIMITATION OF INCIDENTAL OR CONSEQUENTIAL DAMAGES, SO THE ABOVE LIMITATIONS OR EXCLUSION MAY NOT APPLY TO YOU. This Limited Warranty gives you specific legal rights and you may also have other rights that may vary from state to state. This is the only expressed warranty applicable to Ironman-branded products. Ironman neither assumes nor authorizes anyone to assume for it any other express warranty.

PLEASE SEND IN THE ATTACHED WARRANTY CARD WITHIN TEN (10) DAYS OF PURCHASE TO REGISTER YOUR UNIT WITH IRONMAN FITNESS.



Customer Service

1.800.750.IRON

1.800.750.4766

Ironman Fitness

4009 Distribution Drive

Suite 250

Garland, TX 75041

www.ironmanfitness.com